

# Flat bed units



Flat bed unit with Z-axis



Flat bed unit with Z-axis and underframe

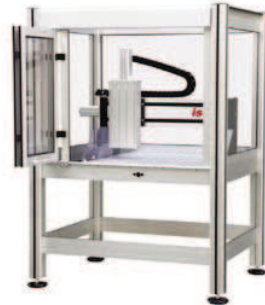

Flat bed unit with Z-axis, underframe and housing

## General note

Flatbed units as defined in the machine guidelines as incomplete machines according to the modular system with processing paths of 250 to 1250 mm. Step motors (MS200HT), set for no-play, are used as spindle drives. Recirculating ball drives with a repeatability of  $\pm 0.02$  mm (positioning reproducibility) are used. The linear guides used are the isel double track feeds, proven over many years, with no-play pre-stressed linear ball bearings and recirculating ball spindles with a repeatability of  $\pm 0.02$  mm. All units are equipped with two limit switches per spindle. The machining and positioning units are available in a number of versions and are characterised by smooth running and high process speeds. The use of high quality aluminium components with flat-milled surfaces achieves low weight and high accuracy. isel X/Y/Z units are the ideal basis for setting up machines and systems for fitting and assembling, pressing and engraving, drilling and milling, milling and screwing, shaping and modelling, bonding and casting, soldering and welding, measuring and checking, sawing and cutting, etc.

## Ordering information

### X/Y flatbed units FB2

Part no.	Chassis A x B (mm)	Clamping surface X x Y (mm)	process travel X x Y (mm)	Z gap (mm)
246203M	1,210 x 946	750 x 850	530 x 500	190
246203 2040M	1,210 x 1,196	750 x 1,100	530 x 750	
246203 2054M	1,210 x 1,446	750 x 1,350	530 x 1,000	
246203 2067M	1,460 x 1,446	1,000 x 1,350	780 x 850	
246203 2130M	1,710 x 1,846	1,250 x 1,750	1,030 x 1250	

All flatbed units are fitted with **16 x 4 mm recirculating ball drives** as standard

### Z-axes for flatbed units

Part no.	Lift (mm)	
230514M	75	with magnet brake 24 V
230514 0400M	160	with magnet brake 24 V

### Underframes

Part no.	suitable for flatbed unit With clamping surface:
248500 0027	750 x 850
248500 0040	750 x 1,100
248500 0054	750 x 1,350
248500 0067	1,000 x 1,350
248500 0130	1,250 x 1,750

### Housings

Part no.	suitable for flatbed units with clamping surface:
248200 0000	750 x 850
248200 2040	750 x 1,100
248200 2054	750 x 1,350
248200 2067	1,000 x 1,350
248200 2130	1,250 x 1,750

# Flat bed units

## Options

- Appropriate Controller (e.g.: iMC-S8)
- Software modules for operating in CAM, CNC and SPS applications
- Underframe
- Housing
- Spindle motors (see pages E-22 et seq.)
- Gap: 300 and 500 mm respectively

## Accessories

Part no.	
<b>219200 0001</b>	Energy guidance chain

## Software

Part no.	
<b>Z11 - 333 500</b>	ProNC Software
<b>Z13 - 337 070</b>	isy-CAM 2.8

## Dimensioned drawings

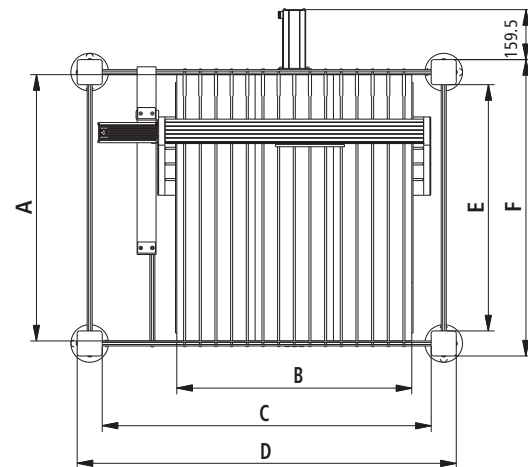
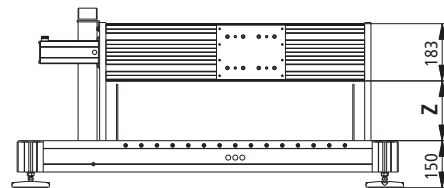
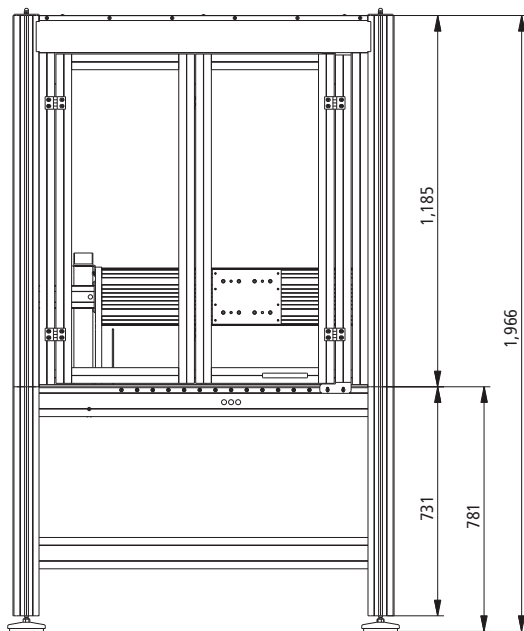

Part-no.	Travel [mm]		Bench clamping area		C	D	E	F	Z
	X	Y	A	B					
<b>246203M</b>	530	500	850	750	1,050	1,210	786	946	190
<b>246203 2040M</b>	530	750	1,100	750	1,050	1,210	1,036	1,196	
<b>246203 2054M</b>	530	1,000	1,350	750	1,050	1,210	1,286	1,446	
<b>246203 2067M</b>	780	850	1,350	1,000	1,300	1,460	1,286	1,446	
<b>246203 2130M</b>	1,030	1,250	1,750	1,250	1,550	1,710	1,686	1,846	

Technical specifications subject to change.