

Linear guide slide function

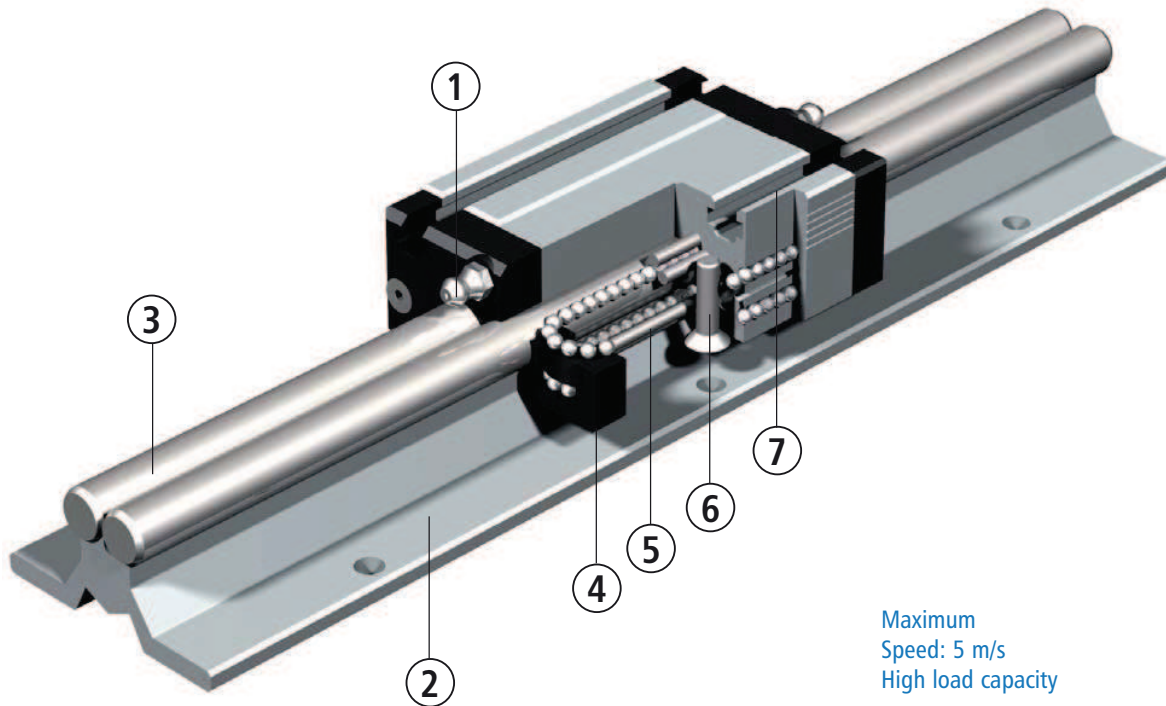

Maximum
Speed: 5 m/s
High load capacity

Aluminium shaft slides

The patented shaft slides are perfectly suited for assembling of complex multiple axis systems for handling and machining.

The wide range of models covers a multitude of applications.

All models can be produced to order with various profile lengths (70, 100, 150 and 200 mm).

1. Lubrication options to both sides for the recirculating balls.
2. The basic supports for all linear guides are extruded aluminium profiles compliant with DIN EN 12020-2, which are provided with T-slot inserts for fastening in the body of the profile or with drilled hole fixing points.
3. Precision steel shafts with a hardness of 60 ± 2 HRC are used as guide rails. All LFS-8 versions are optionally available with stainless steel shafts.
4. The recirculating ball steering systems are glass fibre reinforced.
5. There are patented recirculating balls in the linear slide. Ball bearings run in each case between two ground steel pins and the guidance shaft.
6. The slide is adjusted with self-locking setting screws. This is how the rows of balls and shafts or pins are used with each other and thus prestressed. The slide are preset in the factory to the correct stress. All shaft slides are optionally available in a stainless version.
7. To secure transport loads, slot plates, etc., the shaft slide are provided with T-slot inserts or fixing borings.

General notes

Load capacity and working life

Installation site

In principal, the installation site for linear guides can be chosen anywhere. You merely have to consider whether all the forces and moments arising are below the maximum values for the relevant axes.

Temperatures

All linear guides are designed for continuous operation at ambient temperatures of up to 60 °C. In short-term operation, maximum temperatures of 80 °C are permissible.

Linear guides are unsuitable for temperatures below freezing.

Straightness/Warping

The aluminium profiles used are extruded profiles, which exhibit divergences regarding straightness and may be warped, owing to the manufacturing process.

The tolerance of this deviation is set out in DIN EN 12020-2.

In the worst case, the linear guide deviations equal these limits, but typically they are lower.

In order to achieve the desired guidance accuracy, the guide must be aligned using shims or clamped to a bearing service machined to the corresponding accuracy. This achieves tolerances of 0.1 mm/1000 mm.

Principles

Load capacity and working life

The dimensioning of a linear guide is based on the load capacity of the individual elements. The load capacity is described by:

- the dynamic load factor C
- the static load factor C0
- the static torques M0X, M0Y and M0Z

The basis of the dynamic load factors according to DIN is a nominal working life of 100,000 m displacement path. Far East suppliers often quote load factors for a nominal working life of 50,000 m displacement path; this produces load factor figures which are approximately 20% higher than those according to DIN.

Dynamic load capacity

The fatigue characteristics of the material determine the dynamic load capacity. The working life - the fatigue period - also depends on:

- the stress on the linear guide
- the speed at which the linear guide moves
- the statistical randomness of the first damage occurring

Useful life

Useful life means the working life actually achieved by a linear guide. The useful life may differ from the computed working life.

The following can lead to premature failure through wear or fatigue:

- Misalignments between guide rails or guidance elements
- Contamination of the guide rails
- Insufficient lubrication
- Oscillating motion with very small lifts (formation of grooves)
- Vibrations at rest (formation of grooves)

Owing to the multiplicity of installation and operating relationships, it is impossible to determine the useful life of a linear guide exactly in advance. The safest way to make an accurate estimate of the useful life is, as before, a comparison with similar installations.

Linear guide rail

LFS-12-2



Features

- W 62 x H 31 mm
- 2 precision steel shafts Ø 12
- Anti-twist lock
- Aluminium shaft housing profile, naturally anodised
- High parallelism through patented shaft housing outline
- High guidance accuracy
- Securing from above or below using drilled holes Ø 6.5 in 100 mm raster on flat surface
- Lengths in 100 mm raster
- Max. length up to 2998 mm
- Special lengths to order
- Weight: approx. 3.3 kg/m

Ordering key

235 200 XXXX



Length in mm

e.g. **0298** = Length 298

0998 = Length 998

Profile length = Length overall L - 2 mm

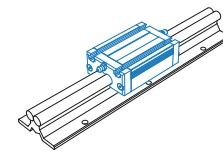

Aluminium slides

- With recirculating ball guide
- Clamping surface plane milled
- Option: stainless steel version

L 94 x W 62 x H 31.5 mm (WS 4/70)

(weight: approx. 0.33 kg)

Part no.: **223104 0070**

Stainless steel: **223104 1070**

L 124 x W 62 x H 31.5 mm (WS 4)

(weight: approx. 0.46 kg)

Part no.: **223104**

Stainless steel: **223104 1000**

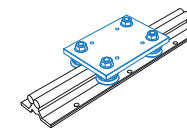

Trolley LW 3

- L 125 x W 85 x H 7.7 mm
- Ground steel plate
- Weight: 0.93 kg

Part no.: **223008**

Load data

Shaft slides WS 4/70	
C ₀	3003 N
C	1873 N
F ₁ static	2821 N
F ₁ dynamic	1599 N
F ₂ static	3303 N
F ₂ dynamic	1873 N
M _x static	29.8 Nm
M _y static	105.3 Nm
M _z static	123.3 Nm
M _x dynamic	16.8 Nm
M _y dynamic	59.7 Nm
M _z dynamic	69.9 Nm

Shaft slides WS 4	
C ₀	4868 N
C	2426 N
F ₁ static	4157 N
F ₁ dynamic	2071 N
F ₂ static	4868 N
F ₂ dynamic	2426 N
M _x static	43.9 Nm
M _y static	155.2 Nm
M _z static	181.7 Nm
M _x dynamic	21.8 Nm
M _y dynamic	77.3 Nm
M _z dynamic	90.5 Nm

Trolley LW 3	
C ₀	2160 N
C	4000 N
F ₁ static	4320 N
F ₁ dynamic	3846 N
F ₂ static	2160 N
F ₂ dynamic	4000 N
M _x static	109.5 Nm
M _y static	194.4 Nm
M _z static	97.2 Nm
M _x dynamic	97.4 Nm
M _y dynamic	173.0 Nm
M _z dynamic	180.0 Nm

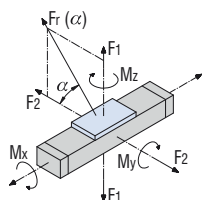

$$Fr(\alpha) = \frac{F_2}{\cos \alpha}$$

$$Fr(\alpha) = \frac{F_1}{\sin \alpha}$$

Linear guide rail

LFS-12-2

Bending

■ Load config. 1

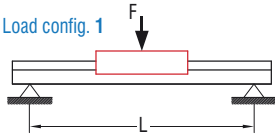

■ Load config. 2

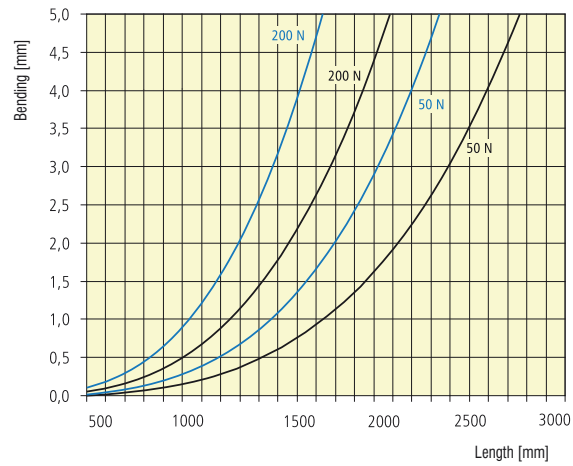
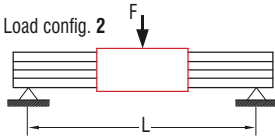

Dimensioned drawings

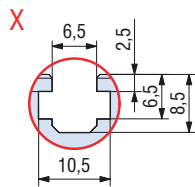
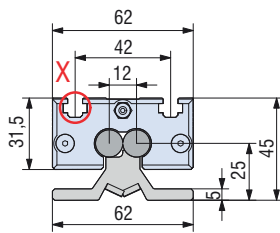

LFS-12-2 with aluminium slides WS 4/70 or WS 4

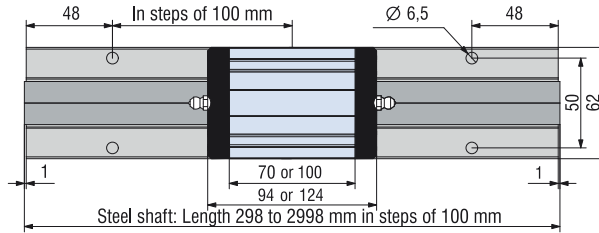

LFS-12-2 with trolley LW3

