

## Indexing table / Rotary unit

## RDH-S



RDH-S as Indexing table  
(solid shaft design)

RDH-S as Rotary unit  
(hollow shaft design)



## Features

- With precision transmission
  - High load capacity, rigid drive bearing
  - Absence of play and high torsional rigidity
- Reduction 1:51 or 1:101
- Stepper or servomotor
- Protection class IP 65
- Stainless design
- Transfer accuracy <math>< 1.5</math> minute of arc
- Repeatability <math>< \pm 6</math> seconds of arc
- Available in solid or hollow shaft design
- No maintenance

For pin assignment see page **B-108**  
For transport loads see page **B-109**

## Ordering key

2 6 6 1 X X 0 X 0 0

## Flanged shaft

0 = solid shaft  
1 = hollow shaft

## Transmission reduction

0 = 101  
1 = 51

## Motors

0 = Stepper motor MS 045 HT with encoder (400 imp., 3-channel, RS422)  
2 = brushless DC servomotor RE 40  
3 = brushless EC servomotor EC 42  
5 = Stepper motor without encoder

## Accessories



## Chuck assembly

3-jaw chuck  $\varnothing$  65

Part no.: **269060 3065\***

3-jaw chuck  $\varnothing$  80

Part no.: **269063 2080\***

3-jaw chuck  $\varnothing$  100

Part no.: **269063 2100\***

\* including flange



## Circular plate

$\varnothing$  150

Part no.: **269 050 0150**



## Tailstock unit RE S

for RDH-S

Part no.: **269100 1020** (200 mm)

Part no.: **269100 1030** (300 mm)

Part no.: **269100 1040** (400 mm)

Part no.: **269100 1050** (500 mm)

## Indexing table / Rotary unit

## RDH-S

## Technical specification

	stepper motor MS 045 HT *		EC servomotor EC 42 (brushless)		DC servo motor RE 40 (with brushes)	
	1:51	1:101	1:51	1:101	1:51	1:101
Reduction ratio	1:51	1:101	1:51	1:101	1:51	1:101
Nominal output speed	[1/min]		[1/min]		[1/min]	
	4	2	22	11	22	11
	at 1500 Hz (225 1/min)		at 1100 1/min		at 1100 1/min	
Max. output speed	[1/min]		[1/min]		[1/min]	
	24	12	59	30	69	35
	at 8000 Hz		--		--	
Nominal torque	[Nm]		[Nm]		[Nm]	
	7	11	4.8	9.2	4.6	9
	at 1500 Hz		--		--	
Max. torque (short term)	[Nm]		[Nm]		[Nm]	
	--	--	7	11	7	11
Rated holding torque (static load)	[Nm]		[Nm]		[Nm]	
	7	11	7	11	7	11
Max. transmission load	[Nm]		[Nm]		[Nm]	
	18	28	18	28	18	28
	Limit for repeatable peak torque					
Dynamic load factor C	[N]		5800			
Static load factor C <sub>0</sub>	[N]		8600			
Weight	[kg]		4.6			

\* Values for half-step operation

## Dimensioned drawings

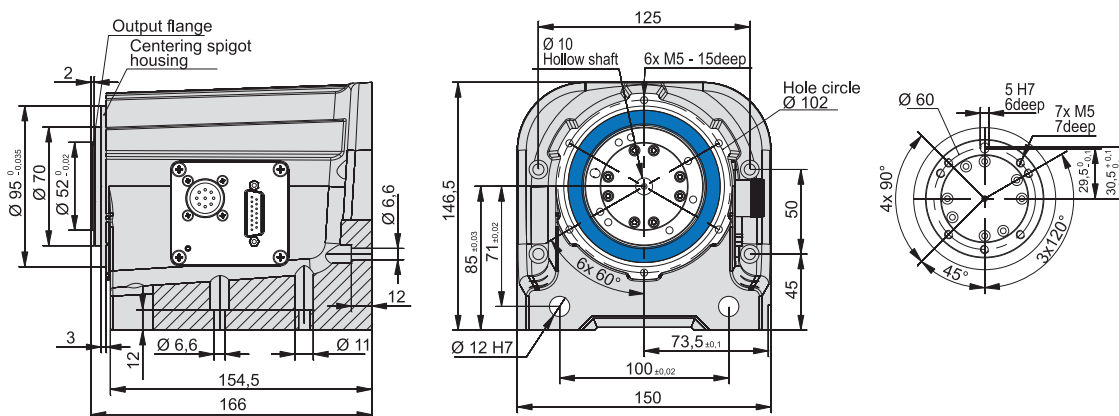

Versions	Part no.	L	A
Tailstock unit RE-S 200 mm	269100 1020	370	128
Tailstock unit RE-S 300 mm	269100 1030	470	228
Tailstock unit RE-S 400 mm	269100 1040	570	328
Tailstock unit RE-S 500 mm	269100 1050	670	428

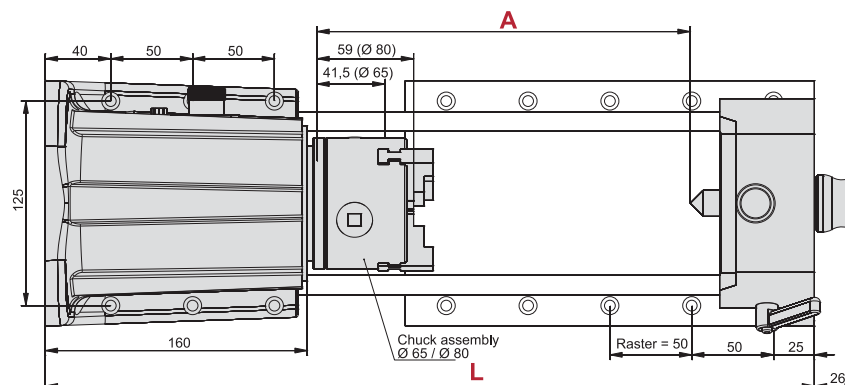

# Motor pin assignments

## Pin assignment for 12-pin stepper motors

(for RDH, DSH-S)

Motor connection

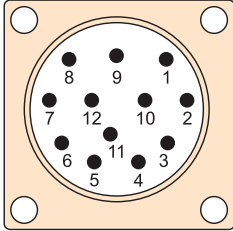

Plug side view of pin insert

M23 12-pin Pin	
1	Motor phase 1A
2	Motor phase 1B
3	Motor phase 2A
4	Motor phase 2B
5	+24V switch
6	+24V brake
7	GND switch
8	GND brake
9	Limit switch 1
10	Limit switch 2
11	---
12	---
Housing - cable shield	

## Pin assignment for 9-pin stepper motors

(for RF1, iZD 54, MD 1, ZD 30, ZR 20, ZDS 2030)

Motor connection

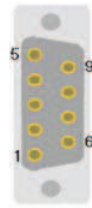

Plug side view of pin insert

Sub-D 9-pin Pin	
1	Motor phase 1A
2	Motor phase 1B
3	Motor phase 2A
4	Motor phase 2B
5	+24V switch
6	+24V brake
7	Limit switch 2
8	GND brake
9	Limit switch 1
Housing - cable shield	

## Pin assignment for stepper motors with encoder

(for RDH)

Motor connection

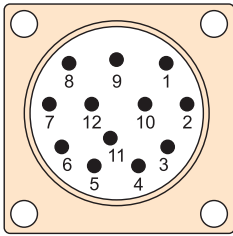

Plug side view of pin insert

M23 12-pin Pin	
1	Motor phase 1A
2	Motor phase 1B
3	Motor phase 2A
4	Motor phase 2B
5	+24V switch
6	+24V brake
7	GND switch
8	GND brake
9	Limit switch 1
10	Limit switch 2
11	---
12	---
Housing - cable shield	

Encoder connection

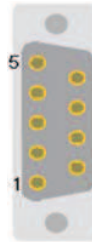

Plug side view of pin insert

Sub-D 9-pin Pin	
1	+5V encoder
2	Encoder track A
3	Encoder track B
4	Encoder track Z
5	---
6	GND encoder
7	Encoder track/A
8	Encoder track/B
9	Encoder track/Z
Housing - cable shield	

## Pin assignment for DC servo motors with brushes (BDC)

Motor connection

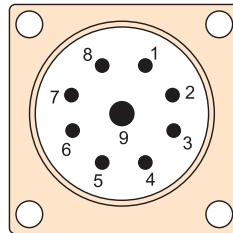

Plug side view of pin insert

M23 9-pol. (8+1) pin	
1	Motor phase 1 (V+)
2	Motor phase 1 (V-)
3	Motor phase 1 (V+)*
4	Motor phase 1 (V-)*
5	+24V brake
6	GND brake
7	---
8	---
9	Earthing lead
Housing - cable shield	

\* Part motor phase connection over 2 wires.

Encoder connection

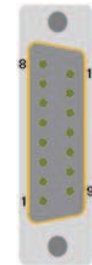

Plug side view of pin insert

Sub-D 15-pin Pin	
1	---
2	+5V encoder
3	Encoder track/Z
4	Encoder track/B
5	Encoder track/A
6	+24V switch
7	Limit switch 1
8	GND switch
9	---
10	GND encoder
11	Encoder track Z
12	Encoder track B
13	Encoder track A
14	Reference switch
15	Limit switch 2
Housing - cable shield	

## Pin assignment for brushless EC servomotors (BLDC) 48V

Motor connection

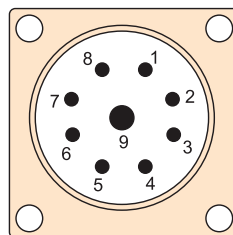

Plug side view of pin insert

M23 9-pol. (8+1) pin	
1	Motor phase U
2	Motor phase V
3	Motor phase W
4	---
5	+24V brake
6	GND brake
7	---
8	---
9	Earthing lead
Housing - cable shield	

Encoder connection

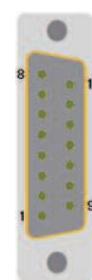

Sub-D 15-pin Pin	
1	Hall signal A
2	+5V encoder/Hall
3	Encoder track/Z
4	Encoder track/B
5	Encoder track/A
6	+24V switch
7	Limit switch 1
8	GND switch
9	Hall signal B
10	GND encoder
11	Encoder track Z
12	Encoder track B
13	Encoder track A
14	Hall signal C
15	Limit switch 2
Housing - cable shield	

Turn/tilt/rotation units:

# Transport loads, machining forces, feed

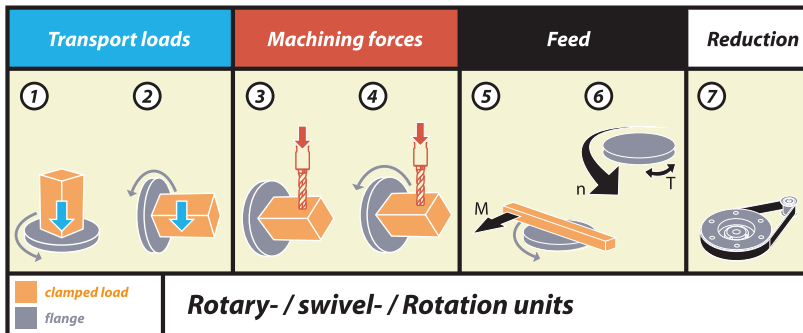

Rotary or tilting units	1*	2*	3	4	5	6	7
RDH-M (step)	100 kg	45 kg	55 Nm	24 Nm	24 Nm	4 rpm	1:51
RDH-M (step)	160 kg	70 kg	108 Nm	45 Nm	45 Nm	2 rpm	1:101
RDH-M (EC-servo, brushless)	110 kg	50 kg	26 Nm	9 Nm	9 Nm	22 rpm	1:51
RDH-M (EC-servo, brushless)	180 kg	80 kg	51 Nm	17 Nm	17 Nm	11 rpm	1:101
RDH-S (step)	30 kg	15 kg	7 Nm	7 Nm	7 Nm	4 rpm	1:51
RDH-S (step)	48 kg	24 kg	11 Nm	11 Nm	11 Nm	2 rpm	1:101
RDH-S (EC-servo, brushless)	30 kg	15 kg	7 Nm	4.6 Nm	4.6 Nm	22 rpm	1:51
RDH-S (EC-servo, brushless)	48 kg	24 kg	11 Nm	4.6 Nm	9.2 Nm	11 rpm	1:101
RDH-S (DC-servo)	25 kg	13 kg	7 Nm	4.6 Nm	4.6 Nm	22 rpm	1:51
RDH-S (DC-servo)	40 kg	20 kg	11 Nm	8.7 Nm	8.7 Nm	11 rpm	1:101
RDH-XS (step)	30 kg	10 kg	5 Nm	5 Nm	5 Nm	24 rpm	1:50
RDH-XS (step)	30 kg	10 kg	7 Nm	7 Nm	7 Nm	12 rpm	1:100
RDH-XS (EC-servo, brushless)	30 kg	10 kg	5 Nm	5 Nm	5 Nm	59 rpm	1:50
RDH-XS (EC-servo, brushless)	30 kg	10 kg	7 Nm	7 Nm	7 Nm	30 rpm	1:100
RDH-XS (DC-servo)	30 kg	10 kg	5 Nm	5 Nm	5 Nm	70 rpm	1:50
RDH-XS (DC-servo)	30 kg	10 kg	7 Nm	7 Nm	7 Nm	35 rpm	1:100
RF 1 (step)	60 kg	30 kg	37 Nm	17.5 Nm	17.5 Nm	50 rpm	1:24
RF 1 (step)	100 kg	50 kg	75 Nm	38 Nm	38 Nm	23 rpm	1:52
RF 1 (step)	150 kg	75 kg	75 Nm	75 Nm	75 Nm	12 rpm	1:100
RF 1 (DC servo/EC servo)	70 kg	35 kg	7 / 12 Nm	6 / 10 Nm	6 / 10 Nm	125 rpm	1:24
RF 1 (DC servo/EC servo)	110 kg	55 kg	16 / 26 Nm	13 / 22 Nm	13 / 22 Nm	58 rpm	1:52
RF 1 (DC servo/EC servo)	160 kg	80 kg	30 / 50 Nm	25 / 42 Nm	25 / 42 Nm	30 rpm	1:100
MD 1 (step)	5 kg	2.5 kg	14 Nm	8 Nm	8 Nm	60 rpm	1:20
MD 1 (DC servo)	6 kg	3 kg	3.9 Nm	3 Nm	3 Nm	175 rpm	1:20
MD 1 (EC servo, brushless)	6 kg	3 kg	4 Nm	3.2 Nm	3.2 Nm	150 rpm	1:20
ZR 20 (step)	10 kg	5 kg	14 Nm	8 Nm	8 Nm	60 rpm	1:20
ZD 30 (step)	14 kg	8 kg	20 Nm	12 Nm	12 Nm	40 rpm	1:30

\*) Guideline values will vary according to application !!