

CNC machine

with servo motor drive

EUROMod®

Features

- space-saving
- fixed portal, movable table
- also available with gantry drive



Interesting application videos
can be found on our YouTube channel.
Just have a look!

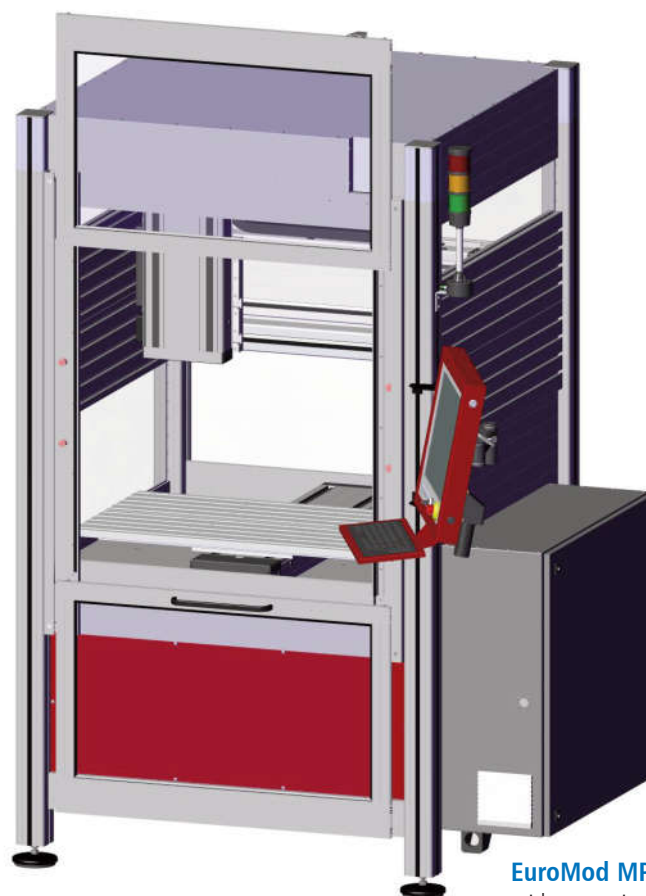

EuroMod MP 45
with operating panel iOP-19-TFT
and open sliding door

Technical Data

* Dimensions with switch cabinet and open door!

	EuroMod MP 30	EuroMod MP 45	EuroMod MP 65
Processing areas X/Y/Z [mm]	610 / 300 / 300	610 / 470 / 300	910 / 650 / 300
Bench clamping area WxD [mm]	900 x 350	900 x 500	1200 x 700
Gap [mm]	365		
Dimensions WxDxH [mm]	1200 x 840 x 2118	1200 x 1150 x 2118	1520 x 1550 x 2118
Dimensions* WxDxH [mm]	1485 x 840 x 2413	1449 x 1150 x 2413	1769 x 1550 x 2413
Processing speed X/Y/Z [mm/s]	max. 250 mm/s		
Repeat accuracy [mm]	± 0,02		
Drive motors	servo motors		
Drive elements X/Y/Z	Ball screws, backlash-free adjustable		
Controller	CAN controller iMD with 3 or 4 drive controllers expandable to 12 axes (max. 6 interpolated & 6 handling axes), iPC, I/O module, PILZ safety PLC with standstill monitoring, power supply 48 V / 1000 W		
Operation	Operating panel iOP-19-TFT		
Weight (kg)	approx. 350	approx. 400	approx. 500
Software	Windows, WinRemote (optional: ProNC, isy 2.8)		
Connection values	230V, 16A		
Part-no.	278010 363443	278011 363443	278012 363443

CNC machine

with servo motor drive

EUROMod®

Features

- Portal aperture: 365mm
- backlash-free adjusted steel KG drives with steel linear guides
- maintenance-free servomotors
- Spindle motors iSA 500 / 750 / 1500 / 1500L and iSA 900 / 1500W / 1500WL / 2200
- Available with and without protective hood
- best suited for multi-shift operation
- swivelling control panel iOP-19-TFT
- Control PC iPC 25 incl. PCI card Win 7 / 64 bit
- network connection

Fields of application

For editing:

- aluminium / light metals
- milled plastics
- wood
- foams
- plexiglass

Options

- PC control panel with free PCI slots (for use with external PCI hardware)
- stainless steel keyboard
- safety light curtain
- Milling and engraving spindles
- Automatic tool changing stations SK11 / SK20
- Minimum quantity lubrication or CoolMin cooling system
- vacuum clamping tables
- suction device
- 4th axis e.g. assembly of the RDH series
- pneumatic sliding door

Overview machine configuration
see page E-20

Dimensioned drawings

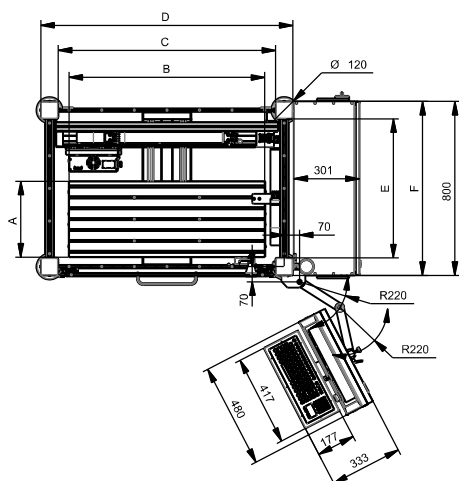
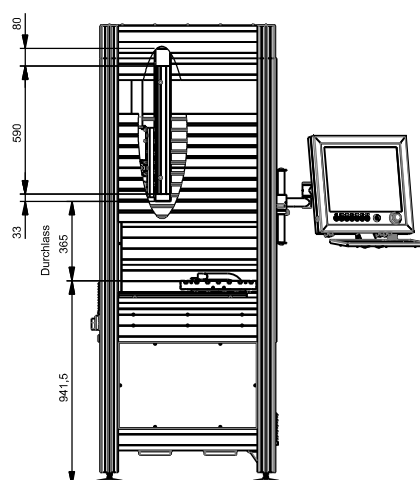
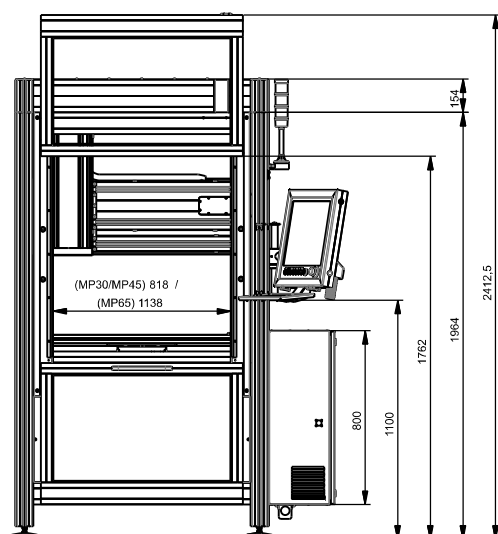

	A	B	C	D	E	F
EuroMod MP 30	350	900	1000	1160	640	800
EuroMod MP 45	500	900	1000	1160	950	1110
EuroMod MP 65	700	1200	1320	1480	1350	1510

Subject to technical changes!